

Audi Genuine Accessories



Audi electric mountain bike

Powered by Fantic | Specifications



Audi electric mountain bike

Powered by Fantic

Technical data

Motor type	Brose S-Mag 36 Volt
Power (Watts)	250
Torque (Nm)	90
Driveline	Pedal assist 32km/h
Transmission	12-speed
Battery	Fantic Integra, Lithium Ion, 36 Volt, 720 Wh
Assistance levels	Eco Tour Sport Boost
Weight including battery	Approx. 23kg

Audi electric mountain bike features

Portable charger with domestic cable	•
Removable Lithium Ion, 36 Volt, 720 Wh battery	•
Battery charging - either when mounted on the bike or removed	•
Handle bar mounted rider display showing various status information	•
Walk assist – helps you push your bike	•
Resistance free pedalling when electric assistance is turned off	•
Unique Audi Sport livery inspired by the Audi RS Q e-tron, Rally Paris-Dakar racing prototype	•
2 Year warranty period*	•

Standard build parts

Frame size and material – Enduro S M L	Hydroformed alloy with carbon seat stays
Suspension front	Fork Öhlins - RXF38 M.2 29, travel 180mm
Suspension rear	Shock Öhlins TTX 22M T205x65, travel 180mm
Front chain ring	SRAM 34t Steel Eagle
Crank arms	FSA Die cast CK-320/ISIS – 155 mm
Rear derailleur	SRAM GX Eagle 12speed
Rear cassette	Sunrace Silver Red 12speed, 11-51

Standard build parts continued

Shift levers	SRAM GX Eagle 12speed
Brake system	Braking IN.CA.S hydraulic disc brake
Front brake rotor	Braking S3 Battfly, 220mm - 6Hole
Rear brake rotor	Braking S3 Battfly, 203mm - 6Hole
Front wheel	Mavic E-Deemax 29" tubeless ready
Rear wheel	Mavic E-Deemax 27" tubeless ready
Front tyre	Vittoria E-MAZZA 29"x 2.6
Rear tyre	Vittoria E-MARTELLLO 27,5"x 2.8
Handlebars	FSA V2 Ø35 800mm - RISE 20
Handlebar stem	FSA 40mm-35 RISE6°
Seat post - dropper	Switch dropper seat post
Seat	Sella Italia Novus Boost EVO

Sizing and geometry (mm)

Frame size – Rider height

- Small: 158 – 168cm
- Medium: 169 – 178cm
- Large: 179 – 188cm

Maximum rider weight:

- 120kg

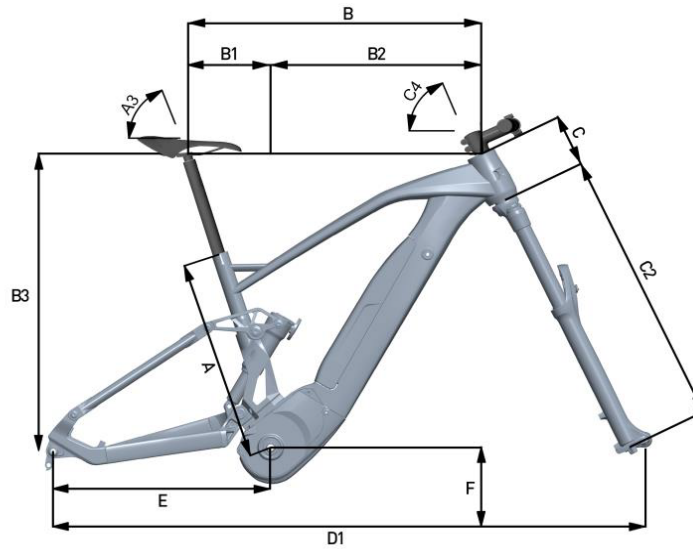

	S	M	L
A (mm)	390	430	470
B (mm)	590	620	650
E (mm)	459	459	459
F (mm)	364	364	364
D1 (mm)	1226	1256	1281
B2 (mm)	414	443	469
B1 (mm)	175.5	177	181
C2 (mm)	596	596	596
C (mm)	105	110	120
A3 (deg)	72	72	72
C4 (deg)	64	64	64.5

* The 24 month warranty period starts from the date of purchase. Some components are covered directly by the component manufacturers warranty (e.g.: motor, brakes, shock absorber, forks). These components are not covered by Fantic's conventional warranty, however your Fantic dealer will be able to provide more information and support.

Audi New Zealand
Level 5, Burns Street
Grey Lynn, Auckland 1021
New Zealand
www.audi.co.nz

The Audi electric mountain bike is approved for use on Non-public roads. Certain restrictions may apply to using a non-road vehicle on public roads or road related areas. Please check with your state or territory transport authority for further information about any requirements. This is a manufacturer's specification sheet and new Audi electric mountain bikes powered by Fantic must be purchased from authorised Audi dealers. Specifications are planned as of Aug, 2023 production and are subject to change without notice or obligation. All information in this specification sheet is correct at the time of publication, however variations may occur from time to time and Audi New Zealand, in so far as it is permitted by law to do so, shall not be liable in anyway as a result of any reliance by any person on anything contained in this specification sheet. For individual pricing and to confirm the specifications of your Audi electric mountain bike please contact your authorised Audi dealer.